

RAB

AUDIO

10

ProRak

Multi-Angle
Rack

12_R

14_R

16_R

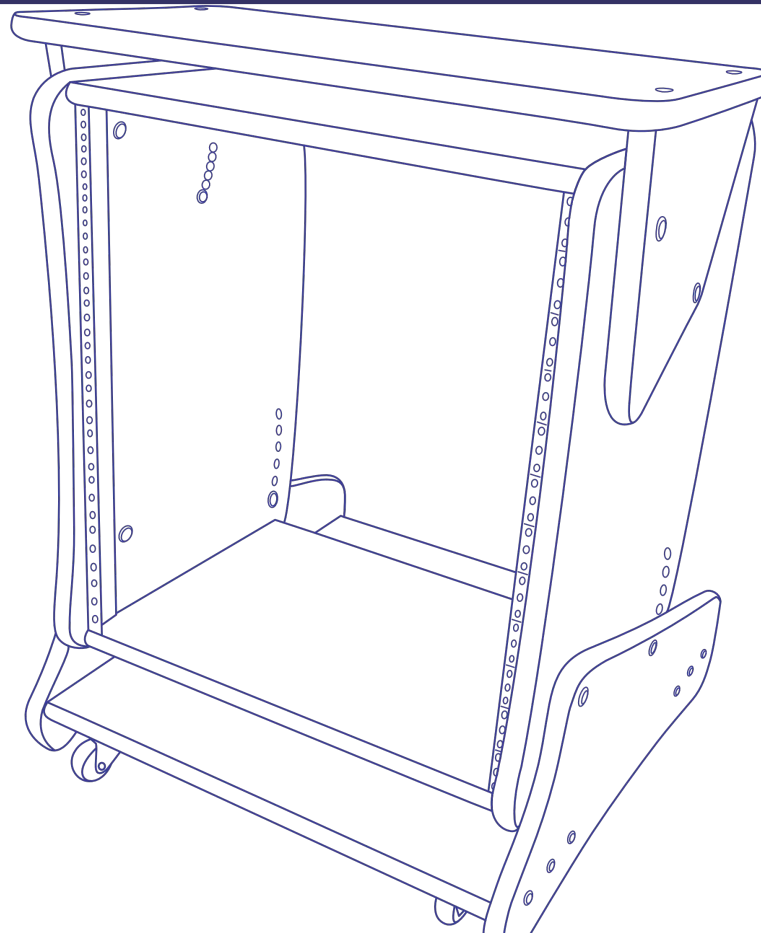

PARTS QUANTITY	DESCRIPTION
2	Sides
2	Feet
2	Caster Bases
2	Bases
2	Angle Adjustable Shelf Sides
1	Shelf Deck
24	Confirmat Screws
16	3/4" Black Screws (for caster assembly)
8	Cap Nuts w/Bolts
12	7/16" Zinc Plated Screws (for mounting rack rails) MA 10, MA 12R, MA 14R
10	7/16" Zinc Plated Screws (for mounting rack rails) MA 16R
2	Rack Rails
4	Casters MA 12R, MA 14R, MA 16R
Tool List	
1	4mm Hex Key

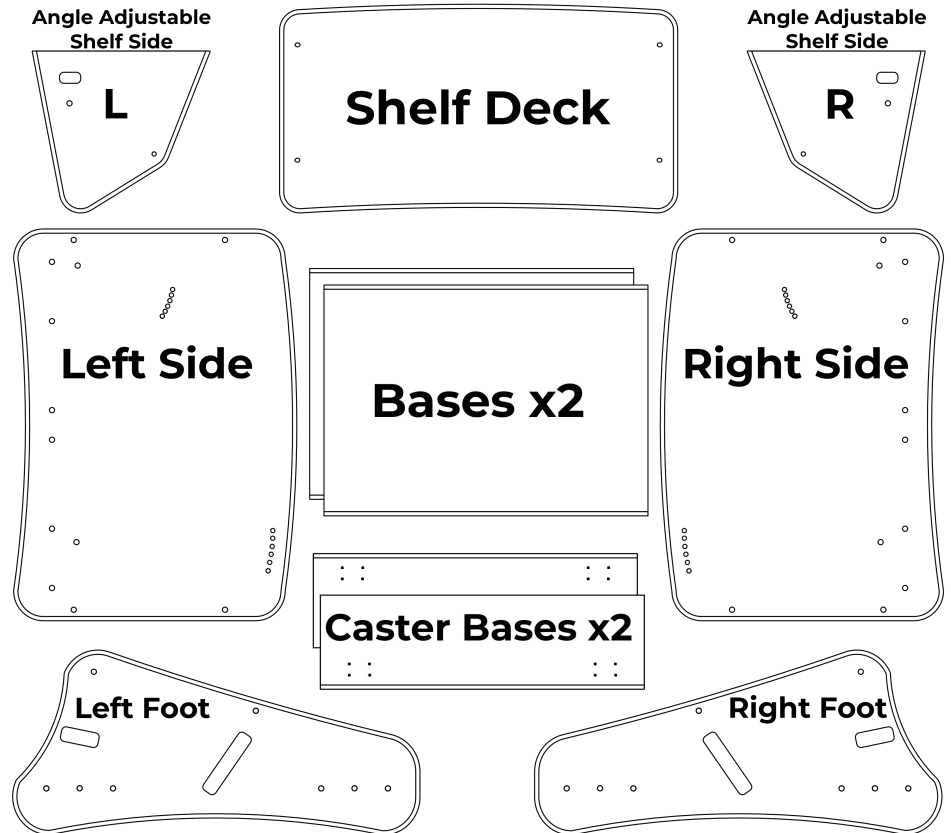

Confirmat Screws

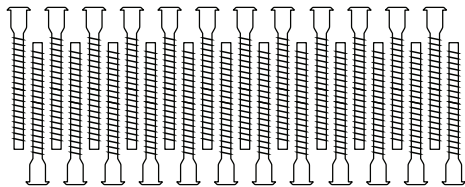

3/4" Black Screws

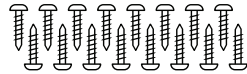

7/16" Zinc Plated Screws



Cap Nuts w/Bolts

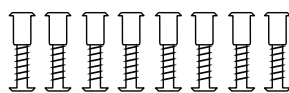

Rack Rail

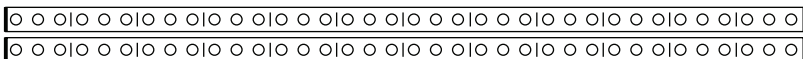

Casters



Diagram reference for steps 2 and 4

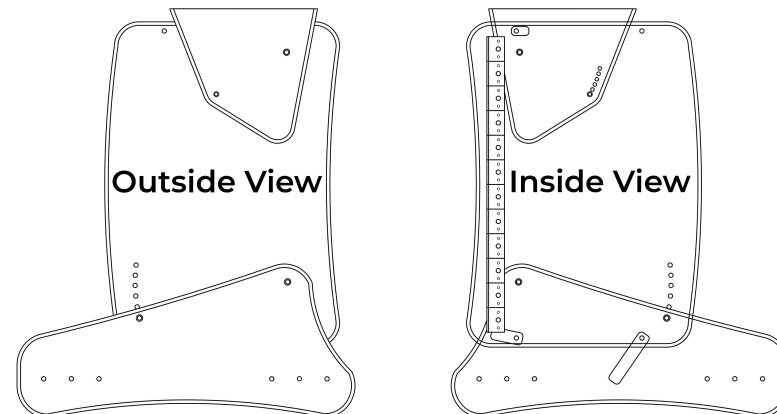

Do not contact your dealer, please visit
www.RABAudio.com/contact-us for parts and services.

ASSEMBLY Step 1 of 4

Tools required: Philips Screwdriver

1. Lay **sides** on a flat surface. Align **rack rails** on pre-drilled holes and secure with **7/16" zinc plated screws**.

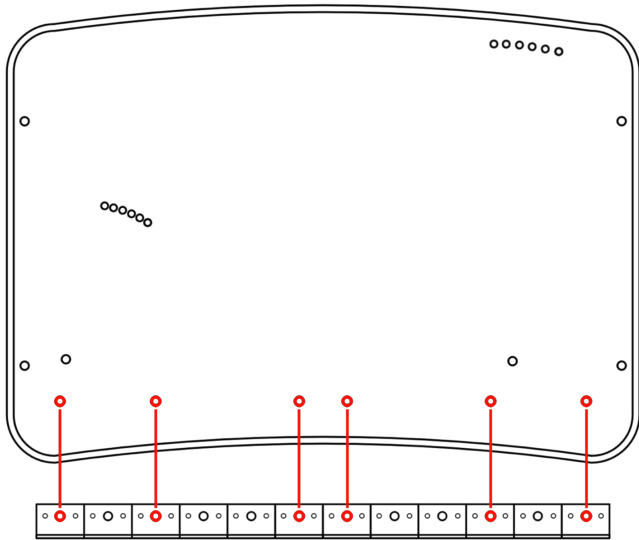

2. Lay **caster bases** on a flat surface. Align **casters** to pre-drilled holes and attach with **3/4" black screws**.
If you have purchased the **MA10** skip this step.

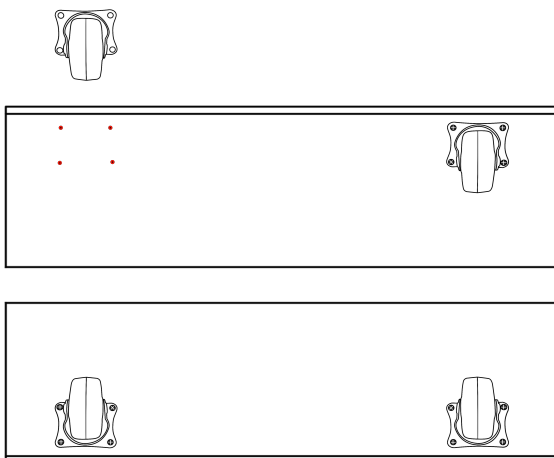

ASSEMBLY Step 2 of 4

Tools required: Hex Key

1. Secure both **bases** to each **racked sides** with confirmat screws.

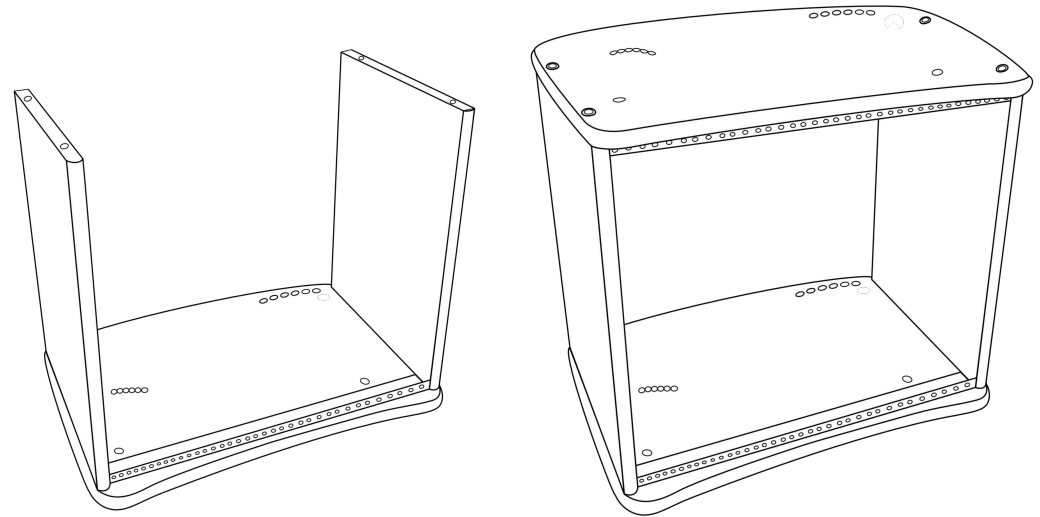

2. Secure **feet** to both **sides** using **cap nuts and bolts**.
Reference diagram on page 2 if you need help with placement.

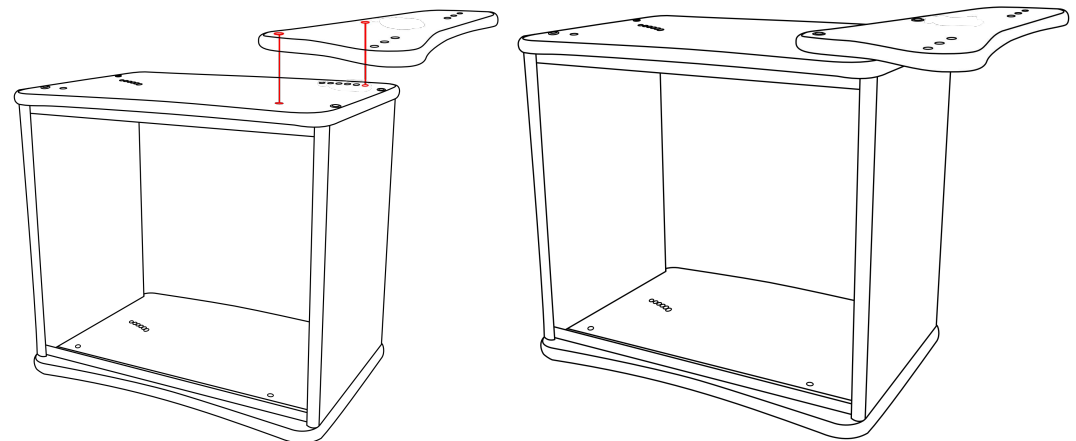

ASSEMBLY Step 3 of 4

Tools required: Hex Key

1. Flip the unit upside down and attach **caster bases** to the **feet** with **confirmat screws**.

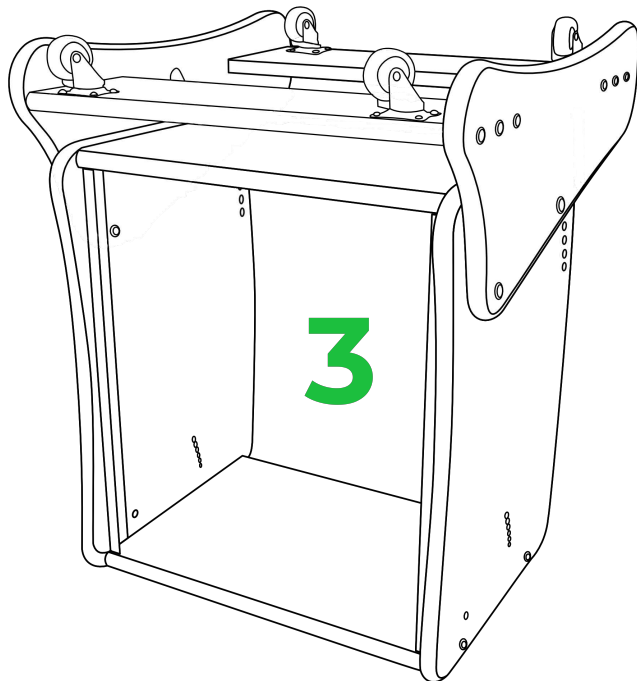
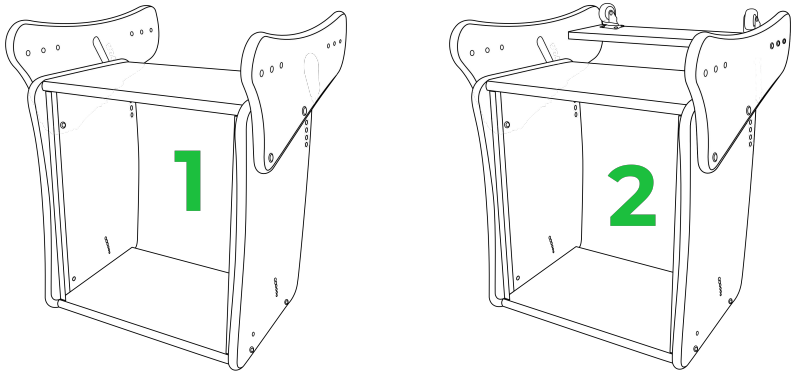

ASSEMBLY Step 4 of 4

Tools required: Hex Key

1. Flip the unit right side up, attach the **angle adjustable shelf sides** to each side with **cap nuts** and **bolts**.

Reference diagram on page 2 if you need help with placement.

2. Lay the **shelf** over the **shelf sides**, secure with four **confirmat screws** and you are finished.

